

A10 Networks Thunder CGN Secured Global IPv4 Addresses for Business Expansion and Enabled a Stable Migration and Operation

The CableTV Co., Ltd., hereafter CableTV, provides cable television, internet access and other broadcasting and telecommunications services in Tochigi, Gunma and Ibaraki prefectures, has adopted a carrier-grade network address translation (CGNAT) solution that enables it to more efficiently use its global IPv4 addresses, with a view to actively expanding its service area. The deciding factors in CableTV's choice of A10 Networks' IPv4 address exhaustion countermeasures/IPv6 migration solution Thunder® CGN were the company's excellent track record in the sector, and the possibility of achieving a much more stable operation.

Within the sector, A10 had an outstanding track record and performance in CGN.

— Tomoyuki Nissato
Manager, Engineering Division, CableTV Co., Ltd



Tomoyuki Nissato
Manager, Engineering Division,
CableTV Co., Ltd



Hideaki Ishikawa
Assistant Manager, Engineering Section #2,
Engineering Division,
CableTV Co., Ltd



Industry | Telecommunications



Network Solution

A10 Thunder® CGN



Critical Issues

- Securing IP addresses to allow business expansion was a matter of urgency
- Making more efficient use of existing assets to avoid reliance on the unpredictable procurement of global IPv4 addresses



Results

- CGNAT resolved IPv4 address exhaustion caused by growth in the number of customers
- Achieved 100 percent availability and stable operation with zero failures in more than 12 months
- Sales increased after switching service from dynamic to static IP addresses



The Challenge: More IPv4 Addresses to Grow the Business

Established in 1987, CableTV provides cable television, internet access, telephone and other broadcasting and telecommunications services in Tochigi, Gunma and Ibaraki prefectures. More than 36 percent of households in this area use CableTV's services, and in Tochigi City in particular, the company has a larger share of the internet access service market than other major carriers.

CableTV is known for its forward-thinking initiatives, and was one of the first in the cable TV sector to adopt fiberoptic (FTTH) network infrastructure. The company pursued an active customer development strategy, focusing on businesses closely linked to local communities such as community television and FM radio stations.

However, as customer numbers grew, a shortage of global IPv4 addresses that users needed to connect to the internet became an issue. Tomoyuki Nissato, manager of the Engineering division, recalls, "For several years, we had been asking the JPNIC to allocate more global IPv4 addresses to us, aiming to secure a larger stock. At the same time we were looking to adopt a CGN solution that would enable us to make more efficient use of our existing addresses."

To obtain new global IPv4 addresses, CableTV had to buy them from other providers, but was finding it hard to secure a steady and regular supply.

Hideaki Ishikawa, assistant manager of the engineering section #2, Engineering division, explains how CableTV came to consider CGN solutions, "As compared with buying new addresses, we felt that adopting CGN, which makes more efficient use of existing IP addresses, certainly enable us to pursue our business with peace of mind."

A Great Reputation: A10 Networks Outstanding Track Record Inspired Confidence with the Customer

While examining different CGN solutions, CableTV's attention was caught by A10 Networks' IPv4 exhaustion countermeasures/IPv6 migration solution, the Thunder CGN. Mr. Nissato recalls, "When comparing solutions, we also emphasized the track record. CGN often came up in conversation at industry gatherings, and A10 Networks' solution was by far the most widely used." When CableTV came to compare CGN solutions, it found out that the initial outlay was higher for other companies' solutions than for the Thunder CGN, and their track record was not as good.

In addition to a strong reputation, CableTV needed a CGN solution that would have high availability and redundancy for a steady operation.

Mr. Nissato said, "Many customers use 1Gbps FTTH, and we needed a CGN solution that would avoid response bottlenecks. We heard that with router-based solutions, in some cases performance declined because of NAT, or game-related applications didn't work properly, so we needed to validate the solution thoroughly."

Other important considerations in the validation process included a requirement to secure a sufficient number of TCP or UDP sessions and flexible NAT traversal for each application through the application-level gateway (ALG) functions in order to cater to the needs of online gaming customers.

Having thoroughly tested the performance of the Thunder CGN using a mock-up network that simulated conditions on its actual network, CableTV confirmed that the solution fulfilled its requirements. Based on this conclusion, a high assessment of its outstanding track record, high performance and cost-effectiveness, the company adopted the A10 Networks Thunder CGN.



The Solution: Thunder CGN Enabled Smooth, High performance IPv4 Exhaustion Counter- measures and IPv6 Migration

A10 Networks' Thunder CGN is a carrier-grade network gateway product that is able to convert addresses and protocols transparently, allowing more efficient use of existing IPv4 addresses and IPv4-based infrastructure, and therefore, protecting investments. It also supports migration to IPv6 networks in a single solution, helping to support gradual migration to IPv6, while extending the life of existing IPv4 addresses.

A10 Networks' Thunder CGN solution incorporates the company's proprietary Advanced Core Operating System (ACOS®), which maximizes hardware performance, enabling high-speed processing of concurrent connections for large-scale sessions. It supports ALG and other functions, making it possible to adopt a high-capacity multilayer NAT structure without affecting existing applications, establishes highly reliable connections, and implements IPv4 address exhaustion countermeasures without diminishing user experience.

The Benefits and Solutions: Smooth Migration and Success in Securing Addresses Vital to Business Expansion

Today, more than 12 months since the Thunder CGN was rolled out, just under 10 percent of all users of CableTV's internet access service have migrated to shared addresses using the Thunder CGN. In the future, the company plans to extend the Thunder CGN to new users while continuing a partial migration of its existing service area.

Mr. Nissato has high praise for the way that A10 Networks' Thunder CGN helped to achieve a substantial reduction in the operational burden. "When there is any kind of alert, we only need to check the number of sessions for IP addresses, and we can operate on a day-to-day basis without touching the management interface. Also, we have never had any difficulty with the CLI, because it uses a Cisco-like command line. It is also easy to change the configuration settings when converting the existing service area to CGN, and it's easy-to-check operational status via the management interface. Since the rollout, we have maintained 100 percent availability with zero failures."

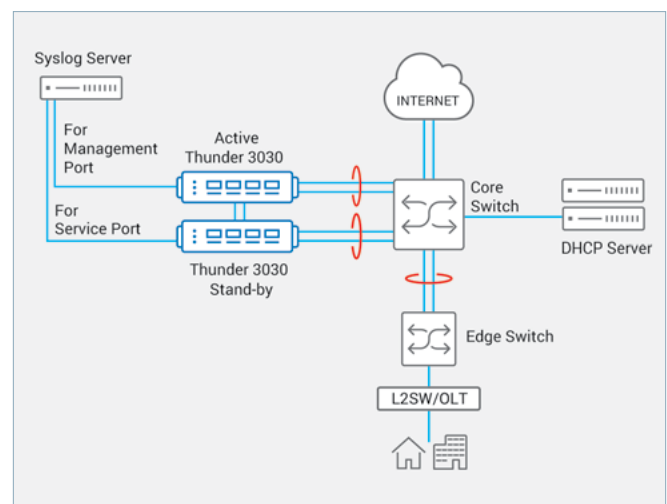

Figure 1: Network configuration diagram

A10 Networks' Thunder CGN enabled CableTV to not only more efficiently use global IPv4 addresses, but also to maintain a high level of service after moving to the CGN. Mr. Nissato said, "The Thunder CGN enabled us to migrate to shared addresses without requiring any conscious effort on the part of our customers. We organized CGN training groups in-house but have otherwise maintained operations unchanged without any particular change to procedures." Until then, CableTV had divided up its global IPv4 addresses, but the Thunder CGN made it possible to use large subnet addresses, as well as reducing the load on network equipment.

For the migration from the existing environment, shared addresses were allocated to users by controlling IP addresses allocated by the DHCP server and shortening lease time. In addition, shared addresses were added to the existing VLAN as secondary addresses, with a view to ensuring that there would be no impact on provisioning coordination. The changeover was achieved without suspending the service itself or implementing any large-scale overhaul.

Deploying Thunder CGN allowed some users who had subscribed to services that had until then used dynamic IP addresses to switch to static IP services, which increased sales. Mr. Nissato describes the unexpected benefits. "For customers who control the source IP address and use VPNs for internal connections, we had many cases where, even with a dynamic IP service, the DHCP server allocated the same IP address. But shared addresses have made it possible to transfer a number of companies to services based on the allocation of static IP addresses."

Looking to the Future: Visualization of Telecommunications, Migration to IPv6

In the future, CableTV plans to not only migrate existing customers to CGN, but to actively attract new customers using shared addresses through A10 Networks Thunder CGN. The company is also considering migration to IPv6, and Mr. Nissato has great expectations of the Thunder CGN.

"It's great that we can migrate products we have already deployed to IPv6 without incurring any additional cost."

CableTV is also considering bolstering and strengthening its security by upgrading to the A10 Thunder CFW solution, which integrates multiple intensive security solutions, including CGN functions, through the visualization of L7 communications and firewall functions. And that is smart business.



About CableTV Co., Ltd.

Founded in 1987, and headquartered in Tochigi, Japan, CableTV Co., Ltd. (CableTV) provides cable television, internet access and other broadcasting and telecommunications services to the Tochigi, Gunma and Ibaraki prefectures.





Find out how to manage
IPv4 exhaustion using CGNAT
IPv6 – Are We There Yet?

[Download eBook](#)



Request a live demo
and experience the
A10 Networks Difference

[Schedule a Demo](#)

About A10 Networks

A10 Networks (NYSE: ATEN) provides secure application services for on-premises, multi-cloud and edge-cloud environments at hyperscale. Our mission is to enable service providers and enterprises to deliver business-critical applications that are secure, available and efficient for multi-cloud transformation and 5G readiness. We deliver better business outcomes that support investment protection, new business models and help future-proof infrastructures, empowering our customers to provide the most secure and available digital experience. Founded in 2004, A10 Networks is based in San Jose, Calif. and serves customers globally.

For more information, visit [A10networks.com](https://www.a10networks.com) and follow us [@A10Networks](https://twitter.com/A10Networks).

Learn More

[About A10 Networks](#)

[Contact Us](#)

[A10networks.com/contact](https://www.a10networks.com/contact)

©2023 A10 Networks, Inc. All rights reserved. A10 Networks, the A10 Networks logo, ACOS, Thunder, Harmony and SSL Insight are trademarks or registered trademarks of A10 Networks, Inc. in the United States and other countries. All other trademarks are property of their respective owners. A10 Networks assumes no responsibility for any inaccuracies in this document. A10 Networks reserves the right to change, modify, transfer, or otherwise revise this publication without notice. For the full list of trademarks, visit: [A10networks.com/a10trademarks](https://www.a10networks.com/a10trademarks).

Part Number: A10-CS-80192-EN-01 MAR 2019